

# Broadsword

**Panel sections** - in full steel, steel/mesh, steel/glass/steel, steel/glass and full mesh.

**Sliding doors** - using low friction bearings for maintenance free operation. Bottom guide rails do not intrude into door opening and make for free access for all types of traffic.

Normally supplied with pull handles, padlock hasp or claw lock. Locks can be provided with Europrofile cylinders.

**Hinged doors** - single or double leaf usually supplied with lever handles, padlock hasp or mortice locks. Locks can be provided with Europrofile cylinders.

See page 11 for door detail.

**Hatches** - drop down hatch with hinged flap that is used as a serving shelf. Sliding hatch for inter communication between areas is available.

**CONSTRUCTION** Broadsword partition panels comprise 40 mm x 40 mm x 2.5 mm thick welded angle frames bolted together with M8 x 16 hexagon head bolts. Panel skin thickness is 0.75 mm/1 mm; mesh size is 50 mm x 50 mm x 3 mm.

Top channel is supplied for lineal stability. Support, where needed, is provided by 80 mm x 40 mm RHS mullions fixed to the floor with M10 expansion bolts. Various mesh types are available on request.

Glazed panels incorporate a 2 piece plastic 'clip-in' glazing bead which accommodates 4 mm and 6 mm glass.

Broadsword partitions are epoxy powder coated or stove enamelled to an average coating of 70 microns. Partitioning is available in the standard colours as shown on page 12. Non-standard and corporate colours are available on request.

**Dimensions** (mm) Available widths are 300, 600, 800, 900, 1000, 1200. Height options are 2438, 2743, 3048 and 3657.

**Weight** is nominally 14 kg/sq m excluding glass.

## Partition types



full steel      steel/mesh      full mesh      steel/glass      steel/glass/steel

## Dimensions

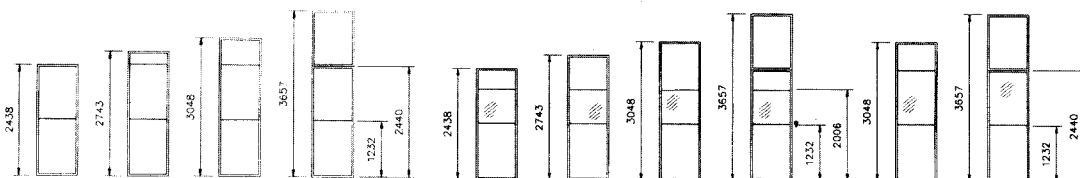

full steel	•	•	•	•						
steel/mesh	•	•	•	•						
full mesh	•	•	•	•						
steel/glass	•	•	•	•						
steel/glass/steel					•	•	•	•	•	•

These elevations are of panels only and do not include for top capping and/or floor track

# Broadsword range - typical assembly

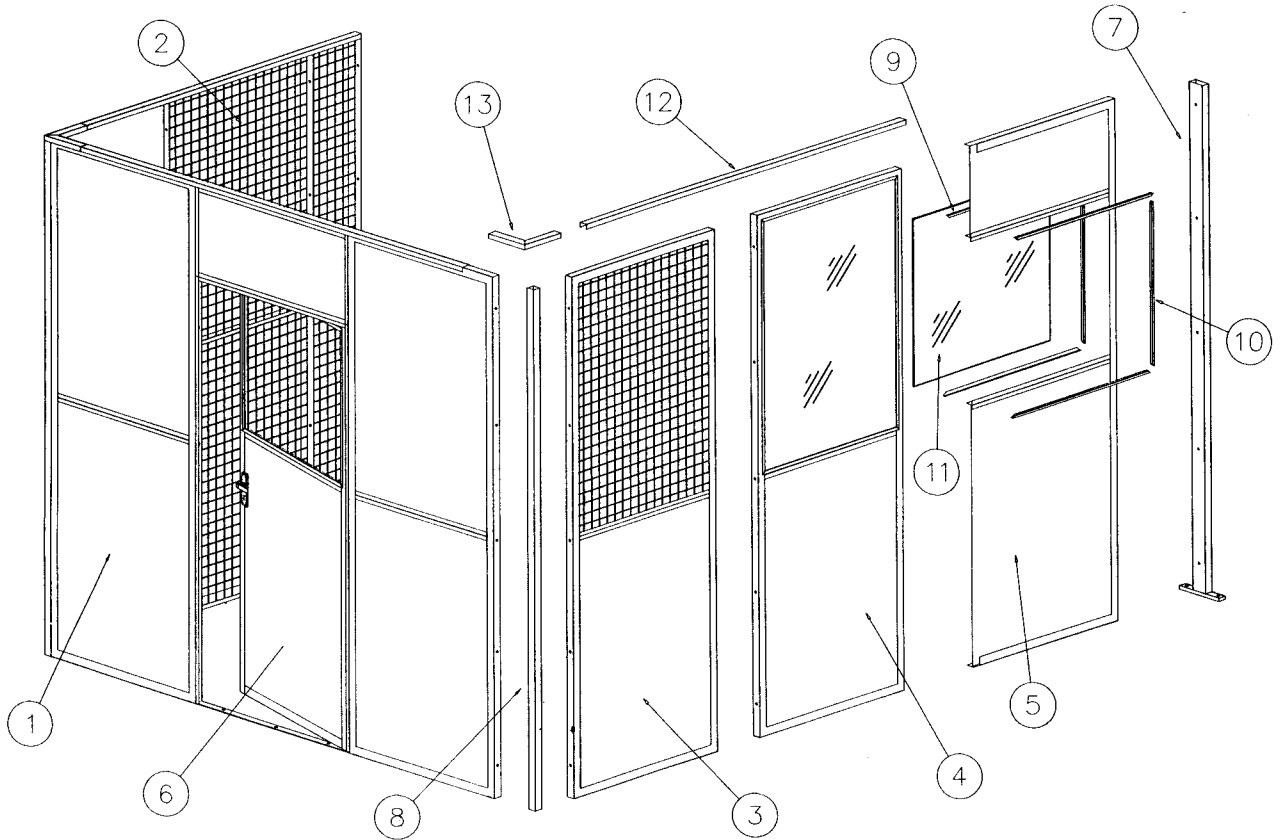

Item	Component	Finish/material	Notes
1	full steel panel	painted finish	width range 300 mm - 1200 mm
2	full mesh panel	painted finish	width range 300 mm - 1200 mm
3	steel/mesh panel	painted finish	width range 300 mm - 1200 mm
4	steel/glass panel	painted finish	width range 300 mm - 1200 mm
5	steel/glass/steel panel	painted finish	width range 300 mm - 1200 mm
6	steel glazed side hung door	painted finish	width range 300 mm - 1200 mm
7	support mullion	painted finish - contrasting colour to panels	900 mm or 1000 mm module
8	corner mullion	painted finish - contrasting colour to panels	80 mm x 40 mm - mullion; locate on 3600 mm centres
9	male type glazing bead	plastic - contrasting colour to panels	40 mm x 40 mm - mullion; used at corners
10	female type glazing bead	plastic - contrasting colour to panels	clips to female bead on inside
11	glazing	glass or plastic	clips to panel framework on outside
12	top capping	painted finish - contrasting colour to panels	various options available to suit application
13	top capping corner section	painted finish - contrasting colour to panels	supplied in 3600 mm lengths right angle 225 mm x 225 mm

## Assembly of junctions

### Straight junction

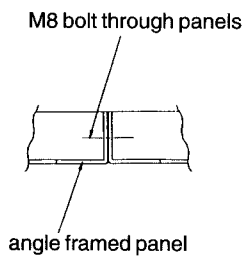

### 3 way T junction

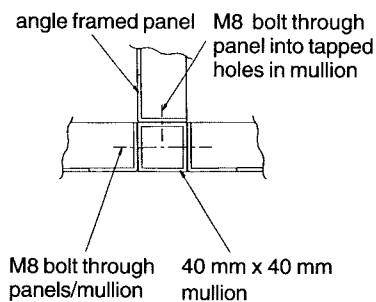

## Glazing bead assembly

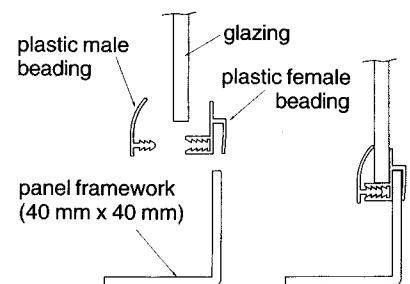

### Corner junction

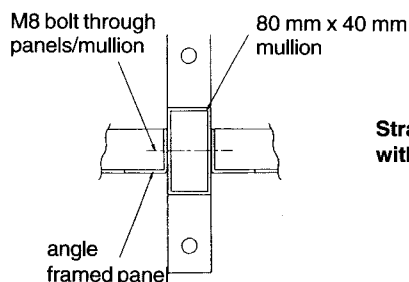
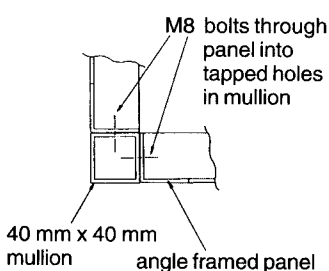

### Straight junction with support mullion

note: diagrams are not to scale